



FEIBA VH Anti-Inhibitor Coagulant Complex Vapor Heated

DESCRIPTION

FEIBA VH Anti-Inhibitor Coagulant Complex, Vapor Heated (AICC) is a freeze-dried sterile human plasma fraction with Factor VIII inhibitor bypassing activity. In vitro, **FEIBA VH** (AICC) shortens the activated partial thromboplastin time (APTT) of plasma containing Factor VIII inhibitor. Factor VIII inhibitor bypassing activity is expressed in arbitrary units. One IMMUNO Unit of activity is defined as that amount of **FEIBA VH** (AICC) that shortens the APTT of a high titer Factor VIII inhibitor reference plasma to 50% of the blank value. The product is intended for intravenous administration.

FEIBA VH (AICC) contains Factors II, IX, and X, mainly non-activated, and Factor VII¹⁻³ mainly in the activated form. The product contains approximately equal unitages of Factor VIII inhibitor bypassing activity and Prothrombin Complex Factors. In addition, 1 – 6 units of Factor VIII coagulant antigen (FVIII C:Ag) per mL are present. The preparation contains only traces of factors of the kinin generating system. It contains no heparin.

Reconstituted **FEIBA VH** (AICC) contains 4 mg of trisodium citrate and 8 mg of sodium chloride per mL.

FEIBA VH (AICC), Vapor Heated has been prepared from Source Plasma and/or Plasma.

The product has been subjected to in-process virus inactivation where vapor is first applied for 10 hours at $60^{\circ} \pm 0.5^{\circ}\text{C}$ and an excess pressure of 190 ± 20 mbar followed by 1 hour at $80^{\circ} \pm 0.5^{\circ}\text{C}$ and an excess pressure of 370 ± 30 mbar. (See Clinical Pharmacology and Warnings sections).

CLINICAL PHARMACOLOGY

In a preclinical study to determine the virus inactivating efficacy of vapor heating, samples of bulk **FEIBA IMMUNO** (AICC) were spiked with 2×10^6 /mL infectious units of HIV and subjected to vapor heat treatment. The residual virus titer was found to be less than 1 infectious unit/0.5 mL. A clinical study⁴ testing Antihemophilic Factor treated by a similar vapor heating procedure has shown none of 4 lots used in the study to produce non A, non B hepatitis in intensively followed patients naive to blood product administration.

The safety and efficacy of **FEIBA IMMUNO** (AICC) has been demonstrated by two prospective clinical trials⁵⁻⁷. The first, conducted by Sixma and collaborators during 1979 and early 1980, was a randomized double-blind study comparing the effect of **FEIBA IMMUNO** (AICC) and PROTHROMPLEX IMMUNO (a non-activated prothrombin complex concentrate) in 15 patients with hemophilia A and inhibitors to Factor VIII. A total of 150 bleeding episodes (primarily joint and musculoskeletal plus a few mucocutaneous) were treated. A single dose of 88 Units per kg of body weight was used uniformly for treatments with **FEIBA IMMUNO** (AICC). The study showed that, based on subjective patient evaluation, **FEIBA IMMUNO** (AICC) was fully effective in 41.0% and partly effective in 24.6% of episodes (i.e. combined effectiveness of 65.6%), while PROTHROMPLEX IMMUNO was rated fully effective in 25.0% and partly effective in 21.4% of episodes (i.e. combined effectiveness of 46.4%).

The second study with **FEIBA IMMUNO** (AICC) was a multiclinic study conducted by Hilgartner et al. It was designed to evaluate the efficacy of **FEIBA IMMUNO** (AICC) in the treatment of joint, mucous membrane, musculoskeletal and emergency bleeding episodes such as central nervous system hemorrhages and surgical bleedings. In 49 patients with inhibitor titers of greater than 5 Bethesda Units (from nine co-operating hemophilia centers), 489 single doses were given for the treatment of 165 bleeding episodes. The usual dosage was 50 Units per kg of body weight, repeated at 12-hour intervals (6-hour intervals in mucous membrane bleedings), if necessary. Bleeding was controlled in 153 episodes (93%). In 130 (78%) of the episodes, hemostasis was achieved with one or more infusions within 36 hours. Of these, 36% were controlled with one infusion within 12 hours. An additional 14% of episodes responded after more than 36 hours.

Of the 489 single doses, only 18 (3.7%) caused minor transient reactions in recipients. 10 out of 49 patients (20%) showed a rise in their inhibitor titers. In 5 of these patients (10%), the rise was tenfold or more. However, of these 10 patients, 3 had received Factor VIII or Factor IX concentrates within 2 weeks prior to treatment with **FEIBA IMMUNO** (AICC). These anamnestic rises have not been observed to interfere with the efficacy of **FEIBA IMMUNO** (AICC).

INDICATIONS AND USAGE

FEIBA VH (AICC), Vapor Heated is indicated for the control of spontaneous bleeding episodes or to cover surgical interventions in hemophilia A and hemophilia B patients with inhibitors.

In addition, the use of **FEIBA IMMUNO** (AICC) has been described in a few non-hemophiliacs with acquired inhibitors to Factors VIII, XI, and XII⁸⁻¹². One case has been reported where **FEIBA IMMUNO** (AICC) was effective in a patient with von Willebrand's disease with an inhibitor¹⁶.

Clinical experience suggests that patients with a Factor VIII inhibitor titer of less than 5 B.U. may be successfully treated with Antihemophilic Factor. Patients with titers ranging between 5 and 10 B.U. may either be treated with Antihemophilic Factor or **FEIBA VH** (AICC). Cases with Factor VIII inhibitor titers greater than 10 B.U. have generally been refractory to treatment with Antihemophilic Factor.

Guidelines to First and Second Choice Treatment:

(AICC) = **FEIBA VH** Anti-Inhibitor Coagulant Complex, Vapor Heated

AHF = Antihemophilic Factor

Patient's Inhibitor	Clinical Situation		
	Minor Bleeding	Major Bleeding	Surgery (Emergency)
less than 5 B.U.	AHF	AHF	AHF
5 to 10 B.U.	AHF	AHF	AHF
	AICC	AICC	AICC
more than 10 B.U.	AICC	AICC	AICC

Inadequate response to treatment may result from an abnormal platelet count or impaired platelet function¹³⁻¹⁵ which were present before treatment with **FEIBA** VH (AICC), Vapor Heated.

CONTRAINDICATIONS

The use of **FEIBA** VH (AICC) is contraindicated in patients who are known to have a normal coagulation mechanism.

WARNINGS

FEIBA VH (AICC), Vapor Heated, is made from human plasma. Products made from plasma may contain infectious agents, such as viruses, that can cause disease. The risk that such products will transmit an infectious agent has been reduced by effective donor screening, testing for the presence of certain current virus infections, by inactivating and/or removing certain viruses. Despite these measures, such products can still potentially transmit disease. Because this product is made from human blood, it may carry a risk of transmitting infectious agents, e.g. viruses, and theoretically the Creutzfeldt-Jacob disease (CJD) agent. ALL infections thought by a physician possibly to have been transmitted by this product should be reported by the physician or other health care provider to Baxter Healthcare Corporation, at 1-800-423-2862 (in the U.S.). The physician should discuss the risks and benefits of this product with the patient.

FEIBA VH (AICC), Vapor Heated must be used only in patients with circulating inhibitors to one or more coagulation factors and should not be used for the treatment of bleeding episodes resulting from coagulation factor deficiencies. It should not be given to patients with significant signs of disseminated intravascular coagulation (DIC) or fibrinolysis.

Thromboembolic events may occur in the course of treatment with preparations containing the prothrombin complex, particularly following the administration of high doses and/or in patients with thrombotic risk factors.

Infusion of **FEIBA** VH (AICC) should not exceed single dosage of 100 units per kg of body weight and daily doses of 200 units per kg of body weight. Patients receiving more than 100 units per kg of body weight of **FEIBA** VH (AICC) must be monitored for the development of DIC and/or symptoms of acute coronary ischemia (see Adverse Reactions section).

High doses of **FEIBA** VH (AICC) should be given only as long as absolutely necessary to stop bleeding.

It has been reported that **FEIBA** VH (AICC) and antifibrinolytics have been given simultaneously without complications. It is recommended not to use antifibrinolytics until 12 hours after the administration of **FEIBA** VH (AICC).

Anamnestic responses with rise in Factor VIII inhibitor titer have been observed in 20% of the cases (see Clinical Pharmacology section).

Individuals who receive infusions of blood or plasma products may develop signs and/or symptoms of some viral infections, particularly non A, non B hepatitis.

PRECAUTIONS

Monitoring of Therapy

If clinical signs of intravascular coagulation occur, which include changes in blood pressure, changes in pulse rate, respiratory distress, chest pain and/or cough, the infusion should be stopped promptly and appropriate diagnostic and therapeutic measures are to be initiated.

Laboratory indications of DIC are decreased fibrinogen, decreased platelet count, and/or presence of fibrin-fibrinogen degradation products (FDP). Other indications of DIC include significantly prolonged thrombin time, prothrombin time, or partial thromboplastin time.

Information for Patients

Some viruses, such as parvovirus B19 or hepatitis A, are particularly difficult to remove or inactivate at this time. Parvovirus B19 most seriously affects pregnant women or immune-compromised individuals. Symptoms of parvovirus B19 infection include fever, drowsiness, chills, and runny nose followed about two weeks later by a rash, and joint pain. Evidence of hepatitis A may include several days to weeks of poor appetite, tiredness, and low-grade fever followed by nausea, vomiting, and pain in the belly. Dark urine and a yellowed complexion are also common symptoms. Patients should be encouraged to consult their physician if such symptoms appear.

Non-Hemophilic Patients

Non-hemophilic patients with acquired inhibitors against Factors VIII, IX or XII may have both a bleeding tendency and an increased risk of thrombosis at the same time.

Laboratory Tests and Clinical Efficacy

Tests used to control efficacy such as APTT, WBCT, and TEG do not correlate with clinical improvement. For this reason, attempts at normalizing these values by increasing the dose of **FEIBA** VH (AICC), Vapor Heated may not be successful and are strongly discouraged because of the potential hazard of producing DIC by overdose.

Pregnancy Category C

Animal reproduction studies have not been conducted with **FEIBA** VH (AICC). It is also not known whether **FEIBA** VH (AICC) can cause fetal harm when administered to a pregnant woman or can affect reproductive capacity. **FEIBA** VH (AICC) should be given to a pregnant woman only if clearly needed.

Pediatric Use

No data are available regarding the use of **FEIBA** VH (AICC) in newborns.

ADVERSE REACTIONS

In the course of treatment with preparations containing the prothrombin complex, thromboembolic events may occur particularly after high doses and/or in patients with thrombotic risk factors.

After application of high doses (single infusion of 100 units per kg of body weight, and daily doses of 200 units per kg of body weight) of **FEIBA** VH (AICC), laboratory and/or clinical signs of DIC have occasionally been observed.

In individual instances myocardial infarction was found to occur after high doses and/or prolonged administration and/or in the presence of risk factors predisposing to myocardial infarction.

As with all human plasma products, any kind of allergic reaction may be seen ranging from mild, short-term urticarial rashes to severe anaphylactoid reactions.

Administration of **FEIBA** VH (AICC), Vapor Heated should be discontinued immediately, if such signs appear. Allergic reactions should be treated with antihistamines and glucocorticoids. Shock should be treated in the usual way.

DOSAGE AND ADMINISTRATION

(See under "For Intravenous Injection or Infusion").

Clinical trials⁵⁻⁷ have demonstrated that the response to treatment with **FEIBA** IMMUNO (AICC) may differ from patient to patient with no correlation to the patient's inhibitor titer. Response may also vary between different types of hemorrhage (e.g. joint hemorrhage vs. CNS hemorrhage).

As a general guideline, a dosage range of 50 to 100 Units of **FEIBA** VH (AICC) per kg of body weight is recommended. However, care should be taken to distinguish between the following four indications, all of which have undergone careful clinical evaluation:

Joint Hemorrhage

In joint hemorrhage, a dose of 50 units per kg of body weight is recommended at 12-hour intervals, which may be increased to doses of 100 units per kg of body weight at 12-hour intervals.

Treatment should be continued until clear signs of clinical improvement appear, such as relief of pain, reduction of swelling or mobilization of the joint.

Mucous Membrane Bleeding

A dose of 50 units per kg of body weight is recommended to be given at 6-hour intervals under careful monitoring (visible bleeding site, repeated measurements of the patient's hematocrit). If hemorrhage does not stop, the dose may be increased to 100 units per kg of body weight at 6-hour intervals. Two such administrations or 200 units per kg of body weight a day should not be exceeded.

Soft Tissue Hemorrhage

For serious soft tissue bleeding such as retroperitoneal bleeding, doses of 100 units per kg of body weight at 12-hour intervals are recommended. A daily dosage of 200 units per kg of body weight should not be exceeded.

Other Severe Hemorrhages

Severe hemorrhages, such as CNS bleedings have been effectively treated with doses of 100 units per kg of body weight at 12-hour intervals. Sometimes, **FEIBA** VH (AICC), Vapor Heated may be indicated at 6-hour intervals until clear clinical improvement is achieved.

Reconstitution

1. Warm the unopened vial containing Sterile Water for Injection (diluent) to room temperature (not above 37°C, 98°F).
2. Remove caps from the concentrate and diluent vials to expose central portions of the rubber stoppers.
3. Cleanse exposed surface of the rubber stoppers with germicidal solution and allow to dry.
4. Open the package of BAXJECT device by peeling away the lid without touching the inside (Fig. a).
5. **Do not remove the device from the package.** Turn the package over and insert the plastic spike through diluent stopper (Fig. b).
6. Grip the package at its edge and pull the package off the device (Fig. b).
7. Turn the system over, so that the bottle is on top. Quickly insert the other plastic spike into the **FEIBA** VH (AICC) stopper (Fig. c). The vacuum will draw the diluent into the **FEIBA** VH (AICC) vial. **Please make sure that the connection of the two vials should be done expeditiously to close the open fluid pathway created by the first insertion of the spike to the diluent vial!**
8. Swirl gently until **FEIBA** VH (AICC) is completely dissolved.

Do not refrigerate after reconstitution!

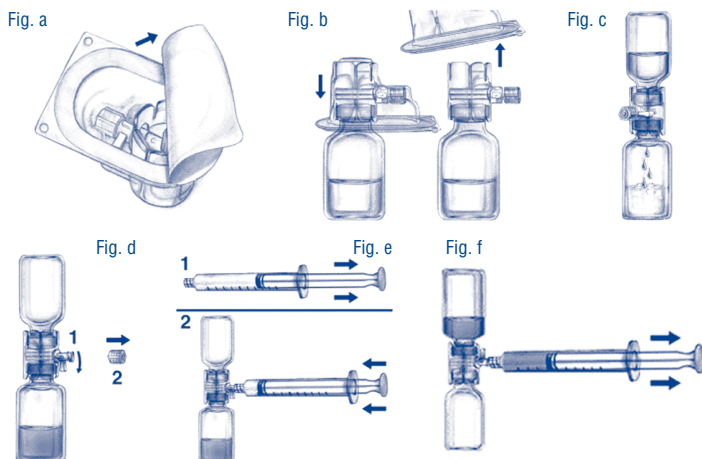

After complete reconstitution of **FEIBA** VH (AICC), its injection or infusion should be commenced as promptly as practicable, but must be completed within three hours following reconstitution.

The solution must be given by intravenous injection or intravenous drip infusion.

Rate of administration

The maximum injection or infusion rate must not exceed 2 units per kg of body weight per minute. In a patient with a body weight of 75 kg, this corresponds to an infusion rate of 2.5 – 7.5 mL per minute depending on the number of units per vial (see label on vial).

For Intravenous Injection or Infusion

1. After reconstituting the concentrate as described under **Reconstitution**, parenteral drug products should be inspected for particulate matter and discoloration prior to administration, whenever solution and container permit. Plastic luer lock syringes are recommended for use with this product since protein such as **FEIBA** VH (AICC) tends to stick to the surface of all-glass syringes.
2. Turn the BAXJECT device handle down towards the **FEIBA** VH (AICC) concentrate vial and remove the cap attached to the syringe connection of the BAXJECT device (Fig. d).
3. Draw air into the syringe, connect the syringe to the BAXJECT device, inject air into the concentrate vial (Fig. e).
4. While keeping the syringe plunger in place, turn the system upside down (concentrate vial now on top). Draw the concentrate into the syringe by pulling the plunger back slowly (Fig. f).
5. Turn the BAXJECT handle to its original position (facing sideways).
6. Disconnect the syringe, attach a suitable needle and inject or infuse intravenously as instructed under **Rate of Administration**.

HOW SUPPLIED

FEIBA VH (AICC), Vapor Heated, is available in single-dose vials in the following nominal potencies:

500 Units (M) per vial (NDC 64193-222-03)

1000 Units (H) per vial (NDC 64193-222-04)

2500 Units (SH) per vial (NDC 64193-222-05)

FEIBA VH (AICC), Vapor Heated, is packaged with a suitable volume (20 mL or 50 mL) of Sterile Water for Injection, U.S.P., one BAXJECT Needleless Transfer Device, and one Package Insert.

Certain components of the packaging material contain Dry Natural Rubber Latex.

The number of Units of Factor VIII inhibitor bypassing activity is stated on the label of each vial.

STORAGE

Store at refrigerated temperature (2° to 8°C, 35° to 46°F).

Within the indicated shelf life, the product may be stored at room temperature (not exceeding 25°C, 77°F) for up to 6 months.

After storage at room temperature, the product must not be returned to the refrigerator.

Please note: If you transfer the product from the refrigerator to room temperature, it expires at the end of the 6 months period or at the end of shelf life, whatever comes earlier.

Record the date on the package prior to shifting the product at room temperature.

Avoid freezing, which may damage the diluent vial.

REFERENCES

1. Elsinger F: Aktivierter Faktor VII in Prothrombinkomplex-Konzentraten. 23rd Annual Meeting of „Deutsche Arbeitsgemeinschaft für Blutgerinnungsforschung“ (DAB), Heidelberg, 1979. F. K. Schattauer Verlag, Stuttgart-New York, 367, 1980.
2. Seligsohn U., Østerud B., Rapaport S. I.: Coupled Amidolytic Assay for Factor VII: Its Use With a Clotting Assay to Determine the Activity State of Factor VII. *Blood* 52: 978, 1978.
3. Seligsohn U., Kasper C. K., Østerud B., Rapaport S. I.: Activated Factor VII: Presence in Factor IX Concentrates and Persistence in the Circulation After Infusion. *Blood* 53: 828, 1979.
4. Mannucci P. M.: Personal communication
5. Sjamsoedin L. J. M., Heijnen L., Mauser-Bunschoten E. P., van Geijlswijk J. L., van Houwelingen H., van Asten P., Sixma J. J.: The Effect of Activated Prothrombin-Complex Concentrate (**FEIBA**) on Joint and Muscle Bleeding in Patients with Hemophilia A and Antibodies to Factor VIII. *The New Engl. J. of Med.* 305: 717, 1981.
6. Roberts H. R.: Hemophiliacs with Inhibitors: Therapeutic Options. *The New Engl. J. of Med.* 305:757, 1981.
7. Hilgartner M. W., Knatterud G. AND THE **FEIBA** STUDY GROUP: The Use of Factor-Eight-Inhibitor-Bypassing-Activity (**FEIBA** IMMUNO) Product for Treatment of Bleeding Episodes in Hemophiliacs with Inhibitors. *Blood* 61: 36, 1983.
8. Thomas T., William. H., Williams Y., Hunt J.: **FEIBA** in Haemophiliacs with Factor VIII Inhibitor. *Brit. Med. J.* 1: 52, 1977.
9. Rolovic Z., Elezovic I., Obrrenovic B.: Life-Threatening Bleeding Due to an Acquired Inhibitor to Factor XII-XI Successfully Treated with **FEIBA**. Proceedings of Joint Meeting of the 18th Congress of the International Society of Hematology and 16th Congress of the International Society of Blood Transfusion, Montreal. Abstract 703, 1980.
10. Dormandy K.: Unpublished data.
11. Vinazzer H.: Personal communication.
12. Preston F. E.: A Review of Cases Treated with **FEIBA** in 1977/78. Presentation at the Second Workshop on Factor VIII Inhibitor Patients, Vienna, 1979.
13. Vermynen J., Sschetz J., Semeraro N., Mertens F., Verstraete M.: Evidence that 'Activated' Prothrombin Concentrates Enhance Platelet Coagulant Activity. *Brit. J. Haematol.* 38: 235, 1978.
14. Semeraro N., Vermynen J.: Evidence that Washed Human Platelets Possess Factor-X Activator Activity. *Brit. J. Haematol.* 36: 107, 1977.
15. Wensley R. T.: General Summary of the Use of **FEIBA** in Haemophiliacs with Inhibitors to FVIII. Presentation at the Second Workshop on Factor VIII Inhibitor Patients, Vienna, 1979.
16. Hilgartner M. W.: Personal communication.

To enroll in the confidential, Industry-wide Patient Notification System, call 1-888-UPDATE U (1-888-873-2838).

Baxter, **FEIBA** and PROTHROMPLEX are trademarks of Baxter AG, Vienna, Austria; Baxter and BAXJECT are trademarks of Baxter International, Inc., registered in the U.S. Patent and Trademark Office.

Baxter Healthcare Corporation

Westlake Village, CA 91362 USA

U.S. License No. 140

U.S. Pat. No. 4,640,834

© 2000 Baxter AG
All Rights Reserved

Revised April/2005